

OPERATION MANUAL

PARADIGM 700VS



7282 SPA ROAD | NORTH CHARLESTON, SC 29418
PHONE: 843-569-2530 | FAX: 843-576-0798
WWW.INLINEPACK.COM

CAUTION!

Persons operating this machinery are reminded to observe their own company safety policies. In addition, the following safety rules should be observed:

DO NOT REACH INTO THE MACHINE WHILE IT IS IN OPERATION.

USE ONLY THE CORRECT TOOL FOR THE JOB BEING DONE.

STAY ALERT, REMEMBER LOCATION OF CONTROL SWITCHES.

MAINTENANCE

The main electric switch supplying power to the machinery should be locked out or disconnected when repairs to work is performed on this equipment.

Machine should be cleaned and inspected regularly. All safety switches must be operable, attachments secure and machine free of broken glass and paper.

Do not hand lubricate when the machine is in operation.

Work area should be kept clean and as dry as is practical.

The repair or adjustment of this equipment should be performed only by persons qualified through technical training and ability, as assigned by your company.

OPERATION

All guards should be securely in place before operating the machine.

Company rules on eye protection should be followed.

Loose clothing or jewelry such as neckties, rolled sleeves, over blouses, bracelets, watches and rings should not be worn when operating the machine.

Report all malfunctions, unusual operation and defects immediately
Please exercise caution with any moving parts, including the conveyor and any pinch or drive rolls.

Stop the machine before placing hands or arms near or into any area where moving parts are located.

TABLE OF CONTENTS

OPERATIONAL AND MAINTENANCE SAFETY RECOMMENDATIONS

SECTION ONE – GENERAL INFORMATION

- 1.1 Terminology of Machine
- 1.2 Specifications and Requirements
- 1.3 Functional Description of Machine
- 1.4 Basic Machine Controls and Screen Settings

SECTION TWO – UNCRATING AND INSTALLATION

- 2.1 Power and Air Connections
- 2.2 Installing in Production Line
- 2.3 Leveling Base of Machine
- 2.4 Adjusting Components of Machine

SECTION THREE – PREPARING FOR OPERATION

- 3.1 Set Conveyor Rails
- 3.2 Adjust Machine Settings
- 3.3 Adjust Sensors

SECTION FOUR – OPERATIONAL ADJUSTMENTS

SECTION FIVE – PERIODIC MAINTENANCE, CLEANING, AND LUBRICATION

- 5.1 Maintenance
- 5.2 Cleaning the Machine
- 5.3 Lubrications

SECTION SIX – TROUBLESHOOTING

- 6.1 Nothing Works at All
- 6.2 Sensor Malfunctioning
- 6.3 Operational Inconsistencies

SECTION SEVEN – OPTIONS AND/OR SPECIAL COMPONENTS SUPPLIED WITH MACHINE

SECTION EIGHT – PARTS LIST AND DIAGRAMS

SECTION ONE – GENERAL INFORMATION

1.1 TERMINOLOGY OF MACHINE

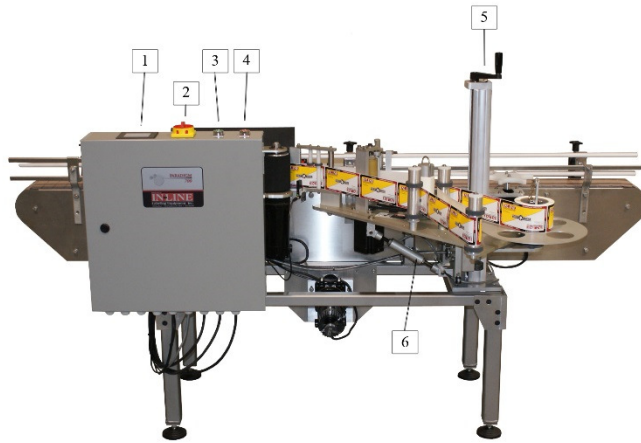

- | | |
|---------------|--|
| 1 PROGRAM | 4 OFF BUTTON |
| 2 MAIN SWITCH | 5 LABEL STATION HEIGHT ADJUSTMENT HANDLE |
| 3 ON BUTTON | 6 LABEL STATION TILT LOCK |

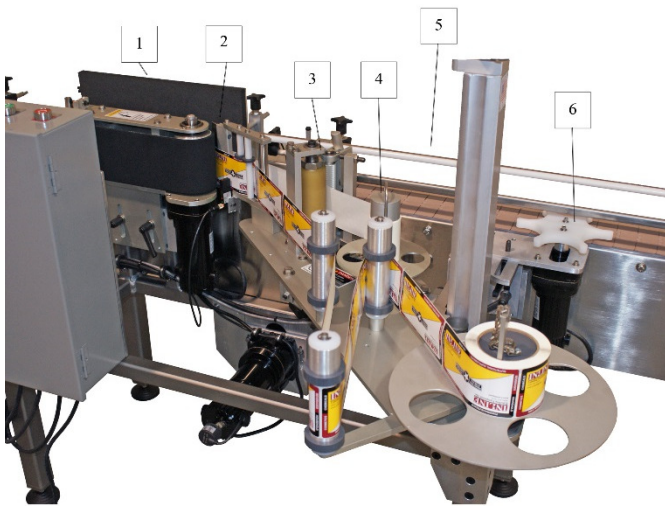

- | | |
|------------------------|----------------|
| 1 WRAP STATION | 4 TAKE-UP REEL |
| 2 PEEL PLATE | 5 GUIDE RAILS |
| 3 PINCH GRIP MECHANISM | 6 STAR WHEEL |

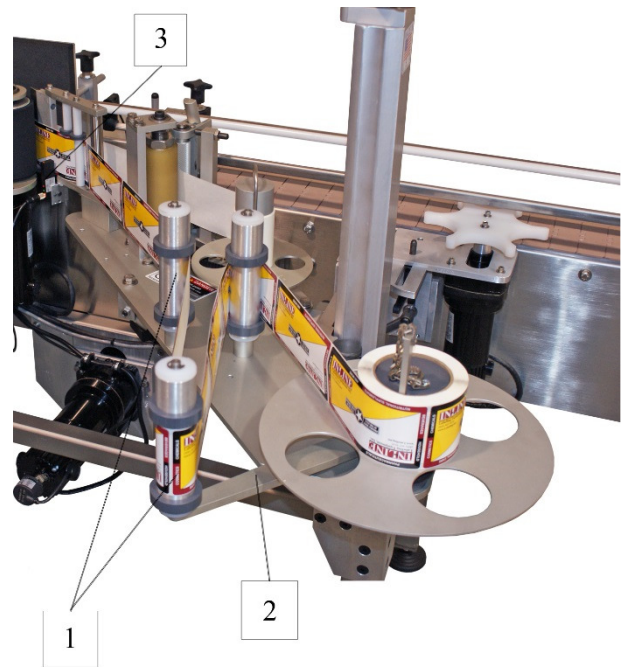

- | |
|--------------------|
| 1 WEB GUIDES |
| 2 DANCER ARM |
| 3 LABEL GAP SENSOR |

1.2 SPECIFICATIONS – STANDARD MACHINE

ITEM	SPECIFICATION
LABEL HEIGHT	1 INCH TO 4.5 INCHES
LABEL WIDTH (LENGTH)	1 INCH TO 14 INCHES LONG
SPEED	VARIABLE TO 1,000 IPM
MAXIMUM RATE	100 LABELS/MINUTE
LABEL GAP	1/8 INCH STANDARD (UP TO ¼ INCH ON SOME)
CORE SIZE	3 INCHES IN DIAMETER
ROLL SIZE	MAXIMUM 12 INCHES
PRODUCT DETECTION	PHOTOELECTRIC EYE
LABEL DETECTION	PHOTOELECTRIC EYE
POWER REQUIREMENTS	120 VAC, 60 HZ, 10 AMP
COMPRESSED AIR	3-4 CFM @ 60 PSI OPTIONAL
CONVEYOR LENGTH	72 INCHES (STANDARD); OTHER LENGTHS OPTIONAL
CONVEYOR HEIGHT	36 INCHES (STANDARD); OTHER HEIGHTS OPTIONAL
CONVEYOR WIDTH	4 1/2 INCHES; OTHER WIDTHS OPTIONAL
CONVEYOR MOTOR	1/10 HP AC GEARED MOTOR

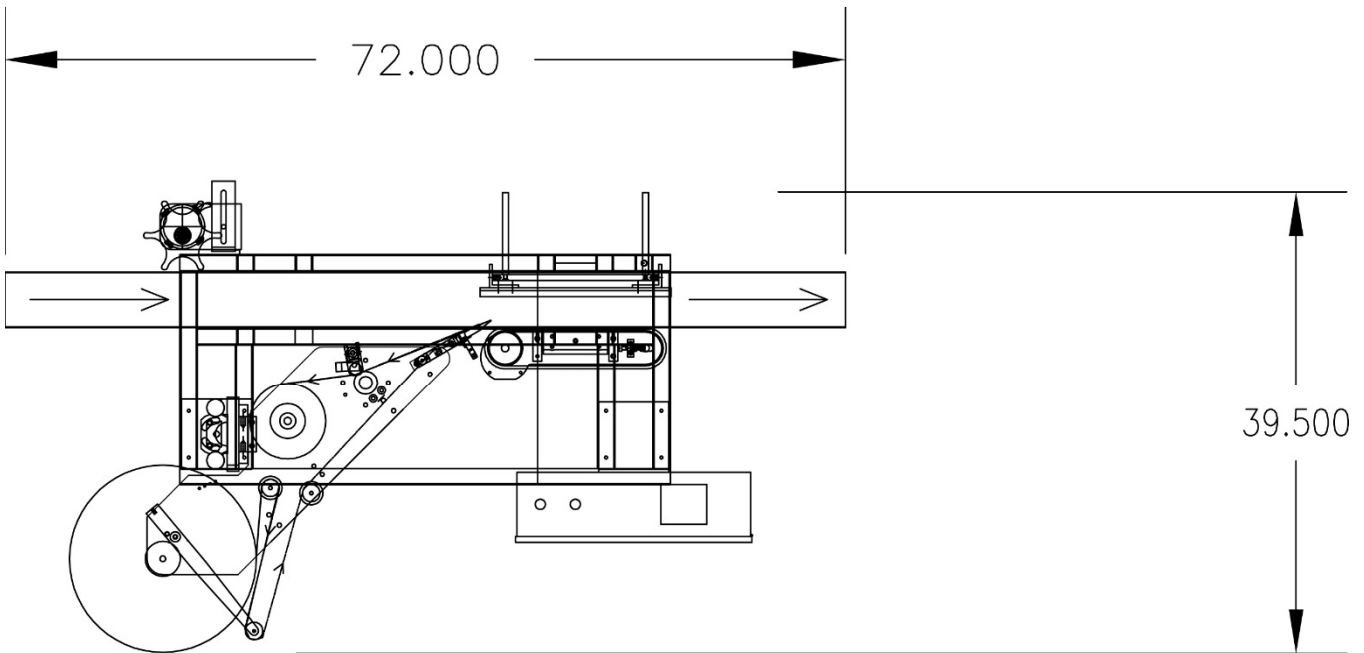

STANDARD LENGTH PD700

1.3 FUNCTIONAL DESCRIPTION OF MACHINE

The Paradigm 700 is a completely new shift from current designs. It can be ordered as one configuration now and easily changed in the future by replacing or adding bolt-on parts. The conveyor height, width, and length can be reconfigured, along with the direction of the machine (left hand or right hand) and one of three labeling styles – wrap, spin-in-place, or trunnion style. So changing your line layout or the packages you run does not make the labeler you already purchased obsolete.

The machine is loaded with nice features; all stainless steel and aluminum construction, off-the-shelf components rather than proprietary boards and motors, a stepper-driven applicator and a standard Touchscreen interface on all models. All speeds on every 700 are synchronized together to avoid common labeling errors, and our Autoset bottle measurement and recipe system ensure easy setups and changeovers. The Paradigm is capable of accuracy to +/- 1/32” depending on the product.

The Paradigm Label Applicator is a fully automatic applicator capable of applying labels to a variety of products. Products to be labeled are sensed as they pass a photo-eye. The photo-eye initiates a signal that is transmitted to the PLC. After a fully adjustable delay, the label is dispensed onto the passing product. For flat panels a wipe brush completes label application by wiping down the label onto the product. For round products, the bottle spins between a powered belt and back compression pad, “wrapping” the label onto the round container. Controls consist of a main power switch, and a Touchscreen operator interface which provides information and access to the label delay, label gap delay, batch count, speeds and more.

1.4 BASIC MACHINE CONTROLS

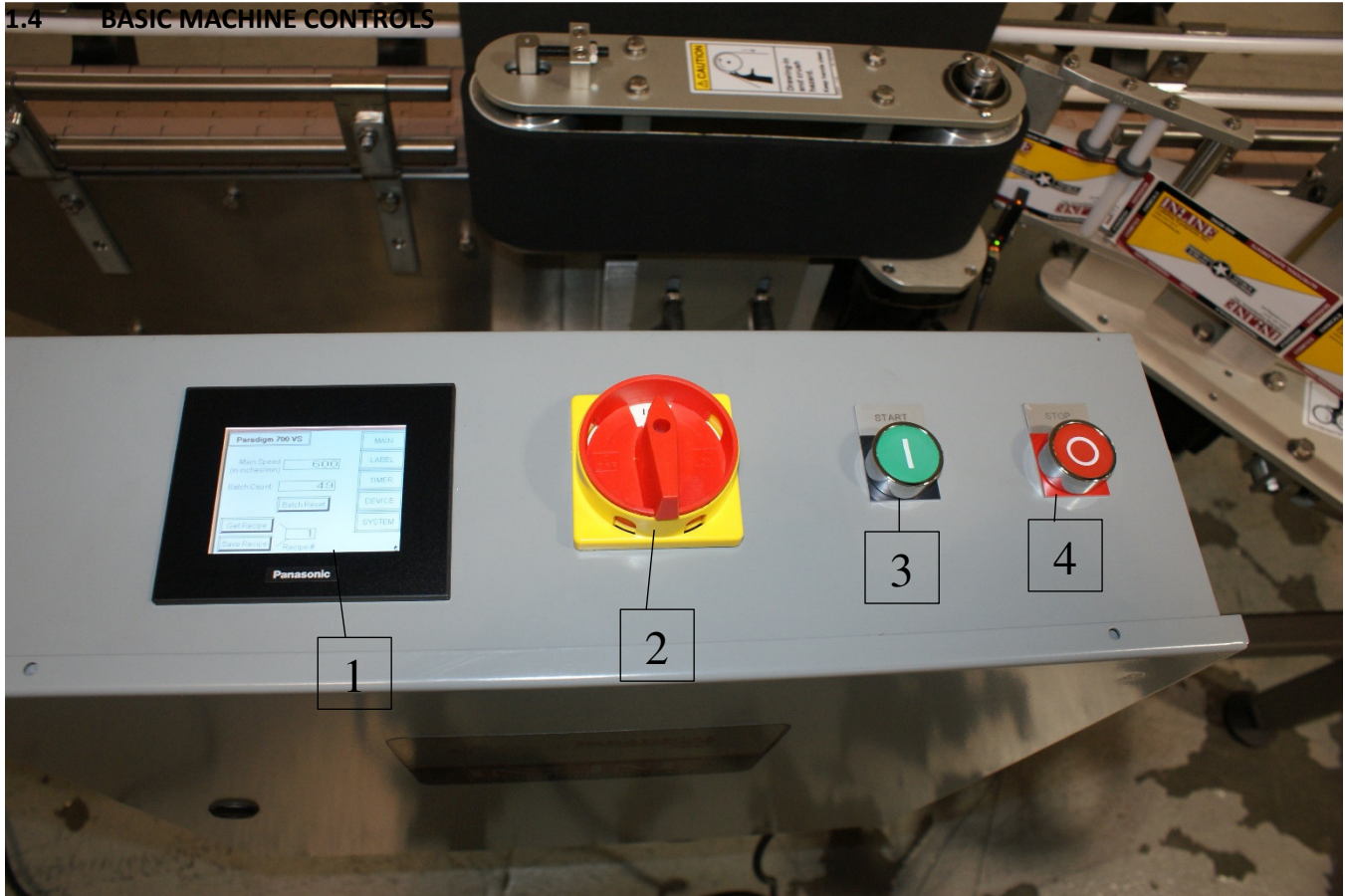

- | | |
|---|-------------------|
| 1 | MAIN INTERFACE |
| 2 | MAIN POWER SWITCH |
| 3 | CONVEYOR START |
| 4 | CONVEYOR STOP |

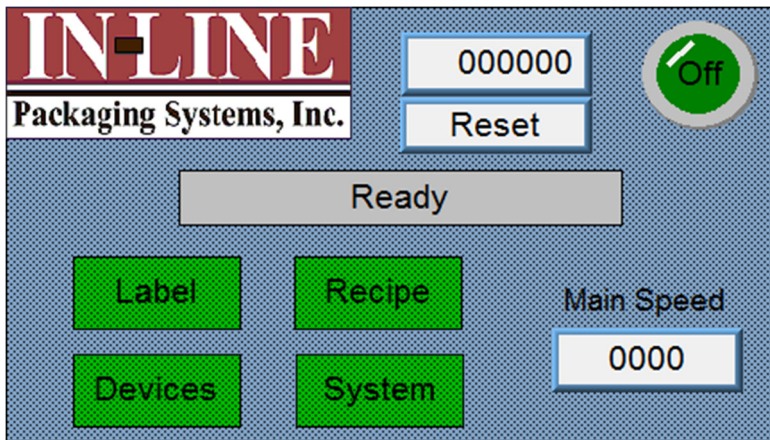

Main Screen

Label: Will take you to the Label Setting Screen

Recipe: Will take you to the Recipe Screen. This is where you can create and save machine recipes

Devices: Will take you to the Device Settings Screen

System: Will take you to the System Settings Screen

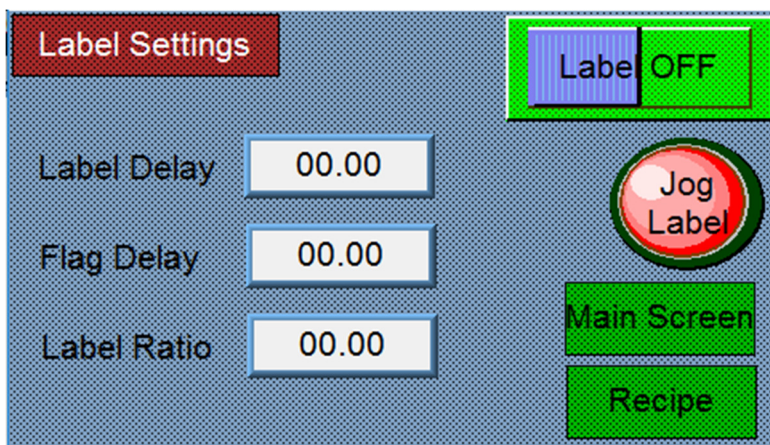

Label Settings

Label ON/OFF: Turns the label function on or off

Label Delay: This setpoint controls the timing in which the label will begin dispensing out towards the product

Flag Delay: This setpoint controls the stop position of the label in relation to the Peel Plate

Label Ratio: This setpoint controls the speed of the label feed

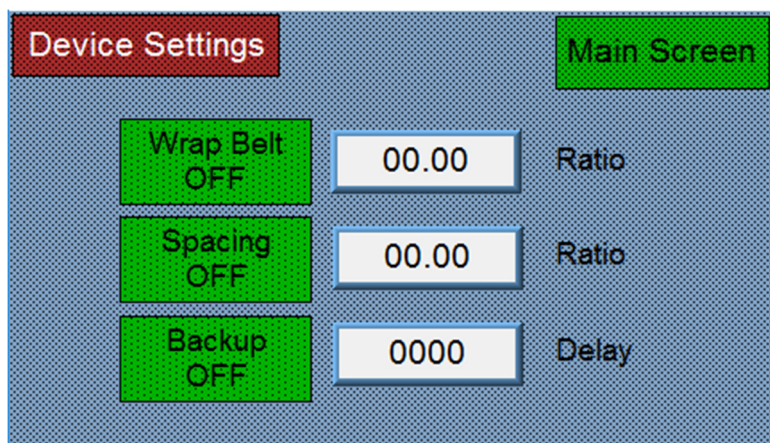

Device Settings

Wrapbelt ON/OFF: Turns the Wrapbelt on or off

Wrapbelt Ratio: This setpoint controls the speed of the Wrapbelt

Spacing ON/OFF: Turns the Spacing Wheel on or off

Spacing Ratio: This setpoint controls the speed of the Spacing Wheel

Backup ON/OFF: Turns the Backup Control function on or off

Backup Delay: This setpoint controls how long the machine will wait before pausing the Spacing Wheel to prevent excess backup

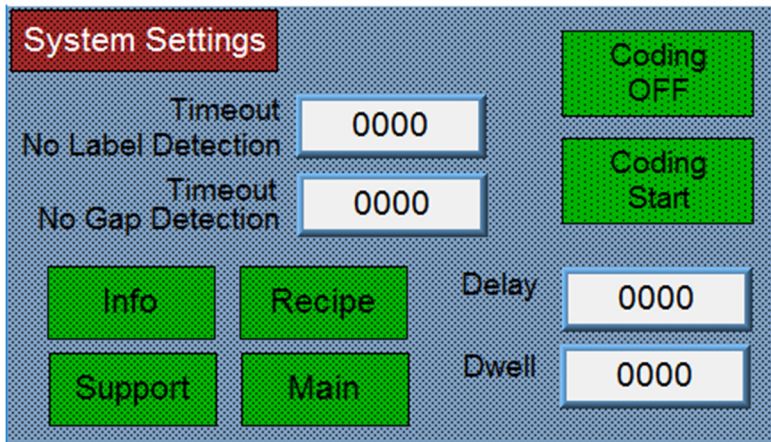

System Settings

Coding ON/OFF: Turns the Coding function on or off

Coding Start: Indicates when Coding is operational

Coder Delay: This setpoint controls the time in which the Coder will print

Coder Dwell: This setpoint controls the time in which the Coder will remain printing

Timeout No Label: This setpoint controls how long the machine will wait till it shuts down due to not detecting a label

Timeout No Gap: This setpoint controls how long the machine will wait until it shuts down due to not detecting a gap in between labels

Info: Takes you to the Info Screen

Recipe: Takes you to the Recipe Screen

Main: Takes you to the Main Screen

Support: Takes you to the Support Screen.

This should only be accessed with the assistance of a technician.

SECTION TWO – UNCRATING AND INSTALLATION

2.1 POWER AND AIR CONNECTIONS

A grounded electrical male plug is provided with the machine, and is connected to the main electrical enclosure on the side of the machine. Plug this into any grounded receptacle. On machines with coders or that require air, an air filter/reservoir with a ¼" male quick disconnect fitting attached, is provided underneath the main electrical enclosure on machines that require compressed air. You can supply compressed air to the machine by either a mating quick disconnect on the end of an air hose, or you can permanently pipe air to the machine using standard pipe and connecting directly into the air filter using threaded pipe connections. If you permanently pipe air into the system we recommend a cut-off valve be mounted at the machine. Some changeover adjustments are easier if the operator is able to temporarily turn off the air pressure.

2.2 INSTALLING IN PRODUCTION LINE

Move the machine into its permanent location. Adjust the conveyor height of the machine to match the heights of the adjoining machines as required. Leveling Pads are provided with the Labeler that allow some vertical adjustment. If necessary, make spacing blocks to raise the height. Approximately 12 inches of lineal space (as a

standard, extensions are available) is provided on each end of the machine to allow a crossover from or to the next machine. Butt the conveyor ends as close to each other as possible and then use conveyor rails to guide the bottles across narrow dead plates onto the conveyor.

2.3 LEVELING BASE MACHINE

Once the machine is installed, level the main conveyor through the machine by using a bubble level. Place the bubble level along the length of the machine and also perpendicular to the conveyor at the label station. Leveling the machine is important to the quality of labeling since this will affect the web path and container path. Verification that the machine is square and level will ensure proper operation.

2.4 ADJUSTING COMPONENTS OF MACHINE

LEVELING LABEL HEAD/SQUARING PEEL PLATE

Next, level the Label Head itself. This is best accomplished by using a small square (or a machined square finish). Place the square on the conveyor and reference it to the end and side of the peel plate.

There are two bolts where the Label Head is mounted to the upright stand. The Label Head pivots around the larger bolt. Loosen both bolts and tilt the label station to achieve the desired adjustment for side-to-side.

Underneath the label station is a turnbuckle adjustment. The Label Station Plate pivots at the point of connection to the upright and when lengthening or shortening the turnbuckle, the front-to-back adjustment of the Peel Plate is changed. Adjust the Label Station to move the Label Head until the end of the Peel Plate and the side of the Peel Plate are both square to the conveyor at the point of labeling. This will ensure that the label is feeding off the Peel Plate in a straight fashion onto the product

2.5 ADJUSTING WIPING PAD

To adjust the Wrap Station, loosen the knobs on the brackets and slide the Wiping Pad back away from the Wiping Belt. Place two containers at each end of the Wrap Station and slide the Wiping Pad in until there is light pressure on the bottles with the leading end (closest to the Peel Plate) slightly more open than the opposite end to ensure container enters the Wrap Station without hesitation. Make sure the Wiping Pad is square to your container by adjusting the knobs that affect the angle of the Wiping Pad. Lock down the adjustment once squareness has been achieved.

The most common reason for skew in the labels is that the Peel Plate is not square to the conveyor, and labels are feeding out crooked in their relationship to the product.

SECTION THREE – PREPARING FOR OPERATION

3.1 SET CONVEYOR RAILS

The conveyor guides must be set to the bottle diameter to ensure smooth control of the containers into and through the labeler. The right side of the labeler is fixed, that is, the side from which the label is applied is fixed to the conveyor. All adjustments to the Conveyor Guides should be from the left side of the machine. Adjust by loosening the knobs holding the rods attached to the rail and then slide the rod in or out. Tighten the handle once complete. The correct distance for a diameter should be about $\frac{1}{8}$ " to $\frac{1}{4}$ " greater than the diameter of the container.

3.2 ADJUST MACHINE SETTINGS

LOADING LABELS ON MACHINE

Now that the main conveyor and Label Head have been leveled, the labels can be loaded as shown in the photo or the diagram on the next page. The web is intended to travel at a height exactly 2 inches above the top plate of the Label Station.

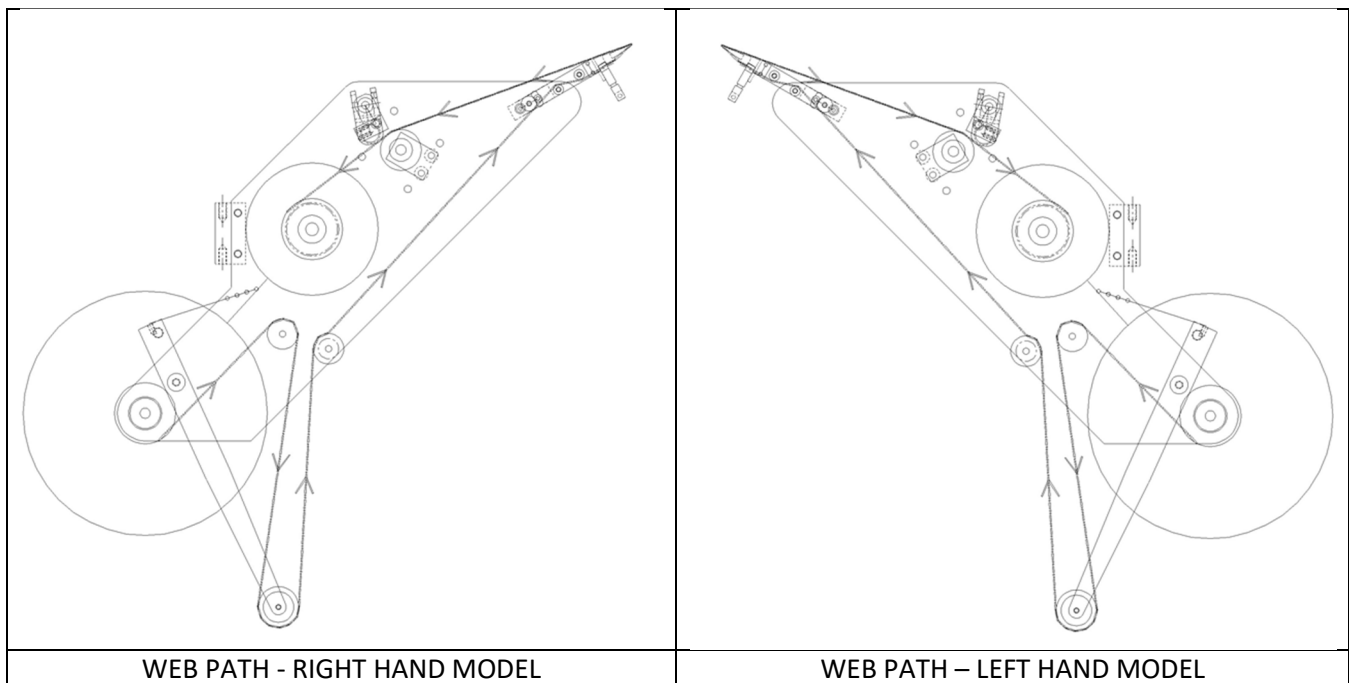

ADJUST HEIGHT OF LABEL ON CONTAINER

The entire Label Station moves up and down to move the label location vertically on the product. Place one of the products to be labeled on the conveyor by the Applicator Roll (with the machine turned off). Now you can use the hand crank located at the top of the stand to adjust the height of the entire labeling head. Adjust until the label is located where you desire.

ADJUST WEB GUIDES

There are several plastic Web Guides on the vertical PVC rolls that guide the web through the machine. These Web Guides help to keep the label web tracking through the machine at the same height. This is essential to consistent labeling. The lower edge of the label web is 2 inches from the top of the Label Plate and so the lower Web Guides should be at that level. These can be measured with a ruler. The top Web Guides can then be moved up or down depending on the height of the label web being run. They should be positioned to allow 1/16" clearance of the web. If the web rides up or down, these guides will help hold it in place.

3.3 ADJUST SENSORS

LABEL GAP SENSOR

The Schneider Gap Sensor has two buttons – a "+" button and a "-" button. To increase sensitivity press the plus button. Each time the button is pressed you will see the right indicator light turn red momentarily. The minus button decreases sensitivity.

The correct operation of the gap sensor is for the yellow indicator light to be on when the gap passes through the fork, and when on the label no indicator light is on.

PHOTO EYE SENSOR

The Leuze product eye has a green indicator light, a yellow indicator light, and a Teach button. Normal operation is for the green indicator light to be on all the time. When the package comes through the yellow indicator light should come on to trigger a label.

There are two teach modes to use. Recommended teach mode is to teach the background as the photoeye sits, and then any package passing through will cause the yellow light to trigger. To do this you press and hold the Teach button. After a few seconds both lights will flash together. Keep holding and then the lights will flash alternating. Release the teach button and it will store this background setting.

SECTION FOUR – OPERATIONAL ADJUSTMENTS

4.1 ADJUSTING LABEL TRACKING AND PRESENTATION TO PRODUCT

The tracking of the label through the machine is extremely important to consistent labeling. If the label web “rides” up or down then the label will generally be skewed to one side or the other. The presentation of the label to the product is also paramount. If the machine is set up correctly, the web will track consistently at the same height through the machine riding on the web guides and around the peel plate and the label will be presented squarely to the wall of the product to be labeled. With it set up this way consistent labeling will be achieved. There are two major factors to consider in labeling consistency:

1.) THE LABEL WEB IS TRACKING UP AND DOWN

This changes the relative height on the product. If this is the case, then uneven pressure or pull is being exerted on one or more points of the web which causes it to move up or down.

Here are some potential points to check:

- The web guides being out of alignment. *(To correct please refer to section 3.4)*
- The pinch roll being out of alignment and putting more pressure or not enough pressure on the bottom (or top) of the web when it pinches. *(Turn the stop screw located at the base of the knurled roll to the right to increase pressure and to the left to decrease pressure.)*
- The take-up reel being too high or low. *(The take-up reel should be 2 inches from the base plate to the top of the take-up reel plate.)*
- The peel plate not being “square”. *(To correct please refer to section 2.4)*
- Pressure in the wrap station causes the bottle to “ride up” or corkscrew up which is reflected in the skew of the label. *(To correct please refer to section 2.5.)*

Any of these factors will cause the label web to establish and track at an angle up or down. The obvious symptom is skew of the labels in a predictable fashion, leaning to one side on the product in the same way as each product that is labeled.

2.) THE SQUARENESS OF THE PEEL PLATE TO THE WALL OF THE PRODUCT

If the peel plate is angled versus the wall of the product, then the label will feed out angled onto the container. This can be checked by using a square placed on the conveyor resting against the very end of the peel plate. Place the square on the conveyor and reference it to the end and side of the peel plate.

There are two bolts where the label head is mounted to the stand. The label head pivots around the larger bolt. Loosen both bolts and tilt the label station to achieve the desired adjustment. Adjust the label station and move the label head until the end of the peel plate and the side of the peel plate are square to the conveyor at the point of labeling. This will ensure that the label is feeding off the peel plate in a straight fashion onto the product. Also check the turnbuckle adjustment.

There will always be some variance from label to label, which is due to the numerous variables of paper, container, machine, etc. In an ideal world the variance will be normally distributed: for example, if 100 products are labeled, the skew will be equally on one side or the other with the average being exactly in the middle (no skew). If plotted, it would appear as a bell-shaped curve. ***If the skew is always to one side or the other then there remains some set-up problem or deficiency that is causing it.***

SECTION FIVE – PERIODIC MAINTENANCE, CLEANING, AND LUBRICATION

5.1 MAINTENANCE

There are very few maintenance items on the 700 Labeler. The three main factors to consider are:

1. Clean the Drive Roll regularly. As the machine is used you will notice a film or line around the black Drive Roll. This is usually from the extra adhesive that has oozed out from under the labels. This buildup of adhesive and dust that sticks to it can create problems with labels sticking to it, or the drive or applicator roll slipping on the product or label. Clean the roll with mineral spirits, or acetone (whatever breaks down the adhesive best) and a clean rag. Doing this regularly will prevent problems. “Goop” hand cleanser and “Goo Gone” also work well. If using a petroleum solvent like acetone or mineral spirits, follow that by cleaning the rolls with a soapy water solution.
2. Drain the Air Inlet Filter and reservoir. Compressed air typically has some condensation in it and your labeler has a drain trap for that. Turn the small knob in to allow the trapped water to drain out every day. The morning is the best time.
3. Periodically the Peel Plate will need to be changed. Paper is abrasive and over time and use will wear the stainless steel Peel Plate. To change the Peel Plate, remove the socket head cap screws and the old plate. Install a new plate and fasten it in place with the socket head cap screws.

5.2 CLEANING THE MACHINE

The 700 Labeler is best cleaned with soapy water or general purpose cleaner. Regular cleaning of the machine is recommended.

5.3 LUBRICATION

The only lubrication points on the machine are:

1. The Web Hub Shaft (Feed Reel) sometimes needs thin oil lubrication to keep it from sticking and the Feed Reel moving freely. Lift it up and apply the oil to the post.

SECTION SIX – TROUBLESHOOTING

6.1 NOTHING WORKS AT ALL

1. Check main power. Is machine plugged in? Is main power switch turned on?
2. Check fuses inside control panel. Bad fuses will be indicated by the red LED on the fuse holder.
3. Are labels loaded in the machine? If the label gap sensor is “open” then an error circuit prevents the motors from turning after 5 seconds.
4. Are speed controls turned up above zero?

6.2 CONTAINER IS DETECTED BUT NO LABEL DISPENSES

1. Is the Label Gap Sensor in the gap between labels or “uncovered”? There is an error feature in the machine that prevents the motors from turning whenever the gap is open for more than 5 seconds.
2. The sensitivity of the Label Gap Sensor may need adjusting. If the Label Gap Sensor is a micro switch it may need adjusting in, if the sensor is a photo eye it may need the sensitivity reduced.

6.3 MORE THAN ONE LABEL IS DISPENSED

1. Check the sensitivity of the Label Gap Sensor. If it is a photo eye then the sensitivity may need to be increased so the photo eye will “see” through the web backing.
2. There may be too much “flag” of label, and the second label is getting stuck to the product and pulling off the web by the product rotation.
3. The photo eye may be set so that the product is being seen more than once, and the machine is labeling the same product again and again. You should be able to see the machine “cycle” in between labels, with a small pause.

6.4 WEB KEEPS BREAKING

1. Check the label web (backing paper). Is it scored, torn, or creased? If so replace with another roll of labels and try again.
2. Check the edge of the Peel Plate. Is there a burr or sharp edge that may be cutting the web? If so then take a piece of emery cloth or very fine sandpaper and lightly sand the edge.
3. Check the travel of the label path. Sometimes the label web may get “hung” on a Web Guide or be binding in a way that will cause the web to break when the Pinch Roll engages. This will cause it to break at the Peel Plate.

6.5 LABEL TRACKING IS NOT SQUARE

1. Check the path of the label web. Is it tracking straight? Are the Web Guides holding the web at a consistent height through the machine? Adjust accordingly.
2. Check Web Guides to ensure that they are holding the label web down.
3. Check the Peel Plate to be sure it is square in relation to the conveyor.
4. Check the Drive Roll to see if adhesive build-up is causing the label web to be pulled up as the label web is pulled through the Pinch Mechanism.

6.6 LABELS ARE SKEWED ON CONTAINER

1. Check the skew to see if it is all the same direction and about the same amount. If so, then check to see if the Peel Plate is square to the container. Use the turnbuckle to adjust the angle of attack of the label.

6.7 LEADING EDGE OF LABEL IS BUCKLING AND/OR TURNED UNDER

1. Are the labels “floppy”, as in film or vinyl label material? This will contribute to this tendency. Check to see if they can be ordered with thicker material.
2. Has the die cut of the label shape creased or scored the web backing. This will “push” the edge of the label into the backing and causes it to hesitate when being separated from the web.
3. Is the label “flagged” too much? If so the incoming product may be folding the edge over.
4. If the label feed begins too early, the leading edge may not be completely attached and it will fold over when it hits the back wiping pad.

6.8 WRINKLES IN THE MIDDLE OF THE LABEL

The transition of the bottle out of the conveyor Guide Rails and into the Wrap Station must be as smooth and as uninterrupted as possible. If the bottle bumps against the edge of the Wiping Pad, a wrinkle will frequently result 1 to 2 inches in from the leading edge. Make sure the bottle moves smoothly through the area where it is detected, where the label feed begins, and when it starts the spin in the wrap station.