

Please goto <http://www.autodwg.com> to register the program, the note will be removed.

700NR Motor Drives

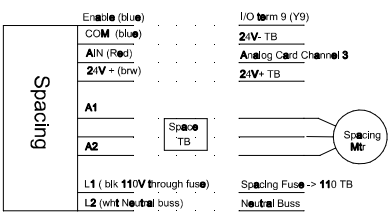

700NR DC distribution

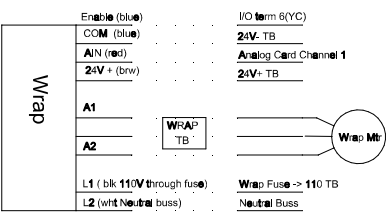
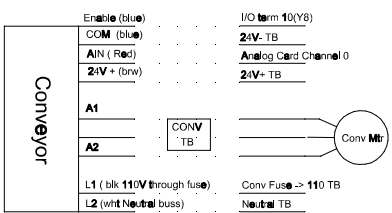
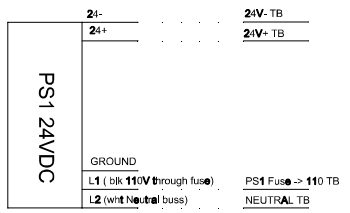
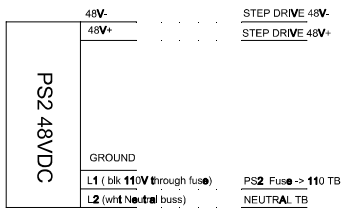
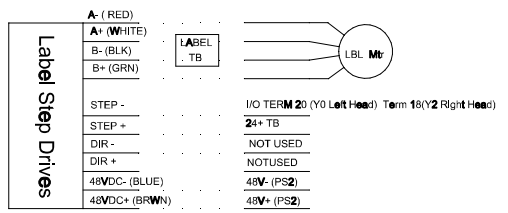

700NR LOGIC I/O

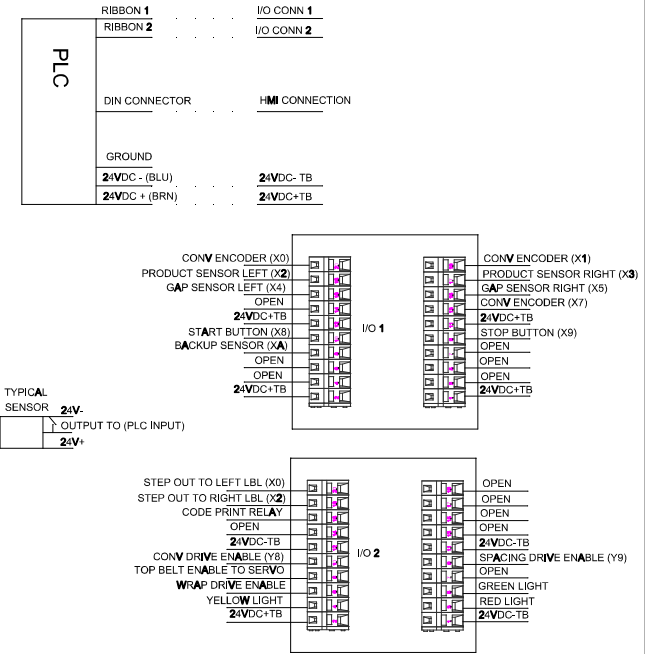

700VS TRUN Motor Drives

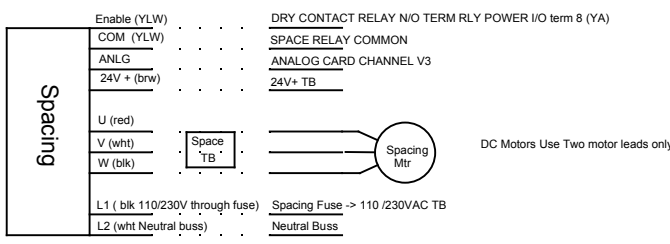
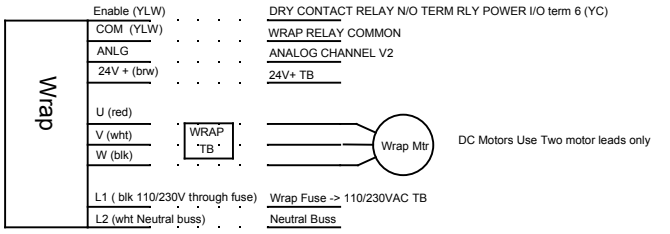
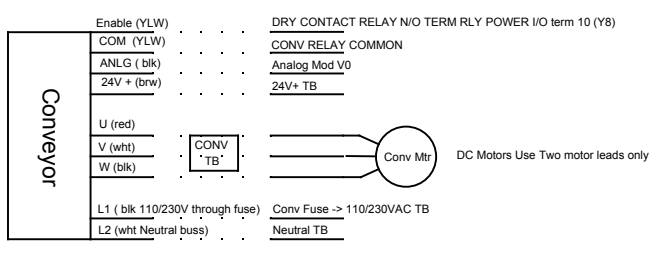

700VS DC distribution

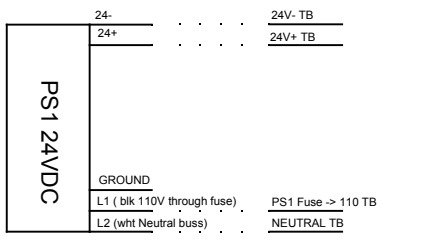
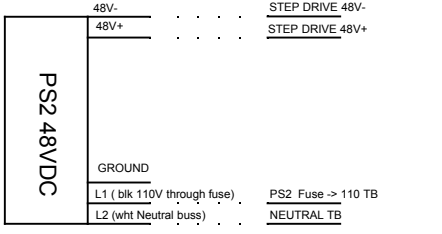
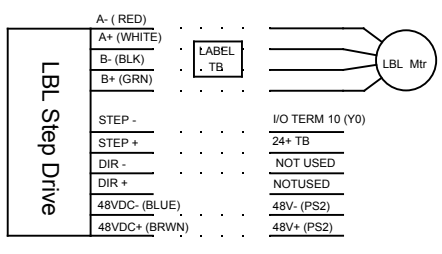

700VS LOGIC I/O

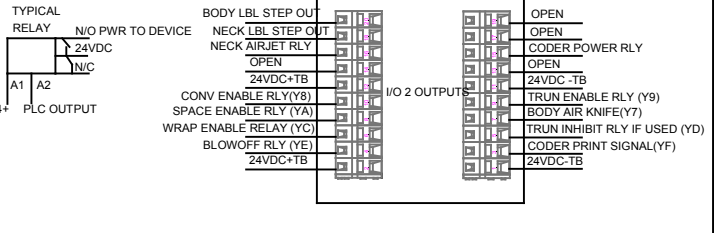
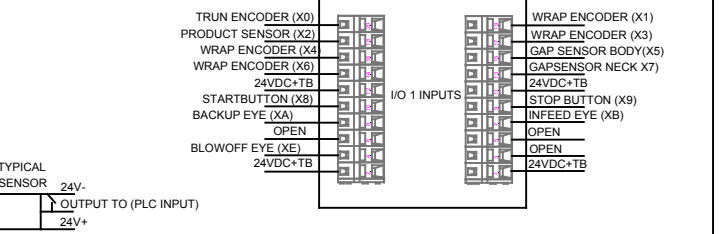
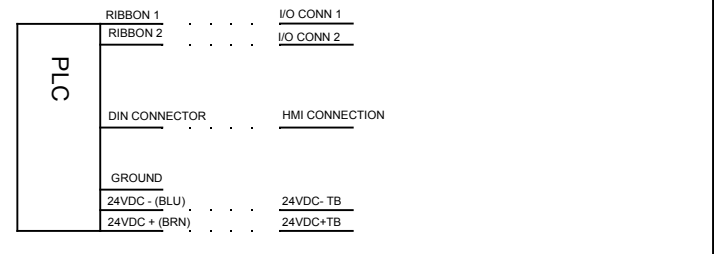

700VS TRUNNION DRIVE

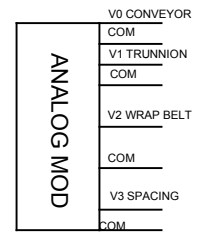
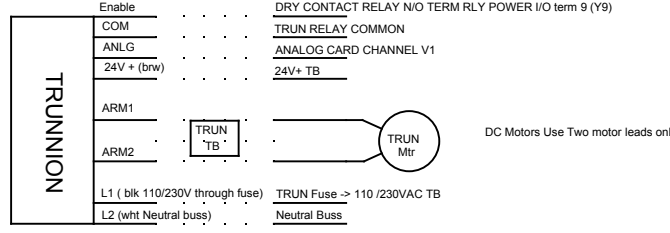

Please goto <http://www.autodwg.com> to register the program, the note will be removed.

700VS Motor Drives

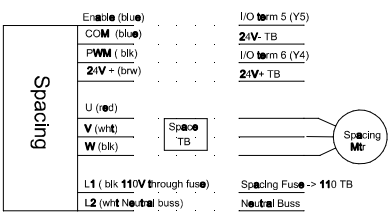
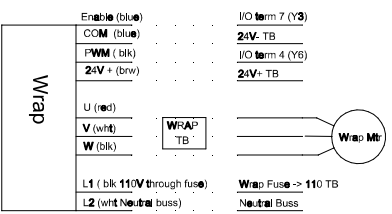
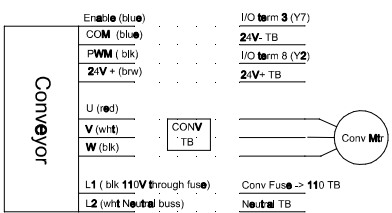

700VS DC distribution

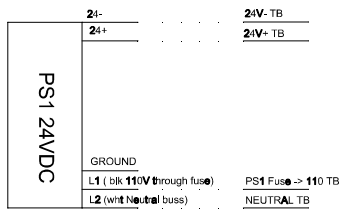
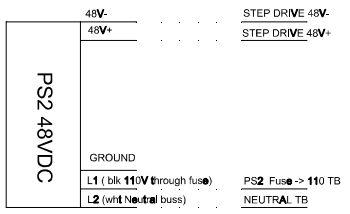
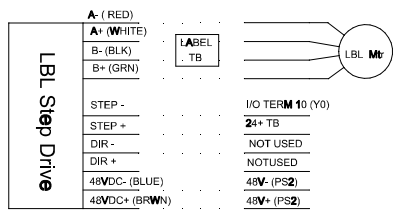

700VS LOGIC I/O

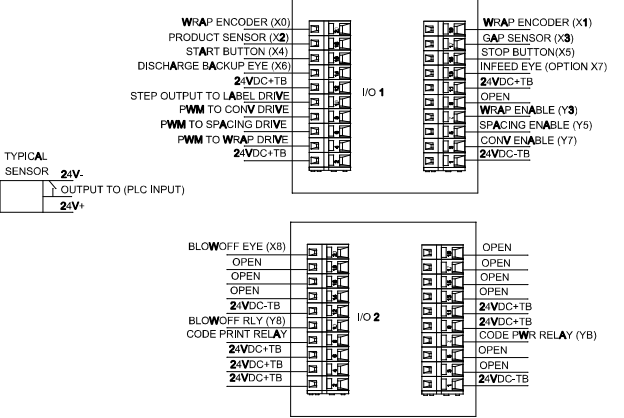
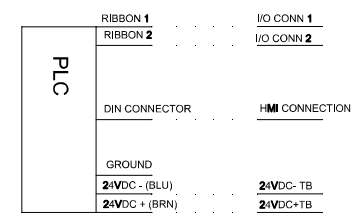

DEPAL PG1

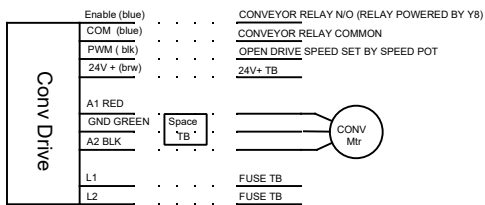
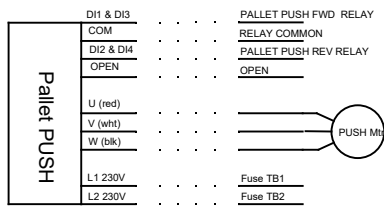
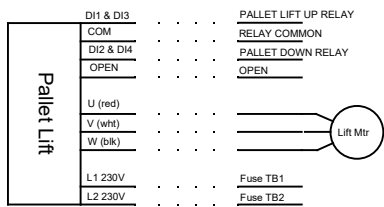

DEPAL PG2

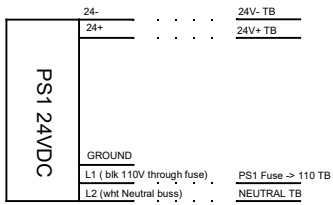
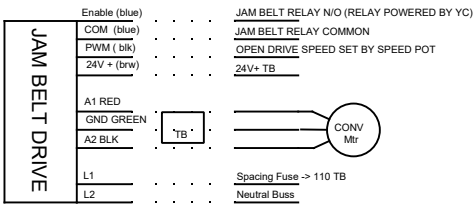
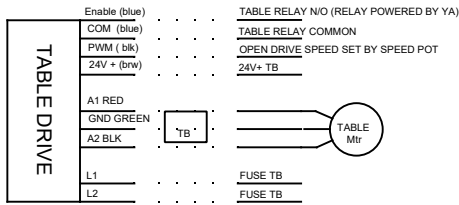

DEPAL PG 3

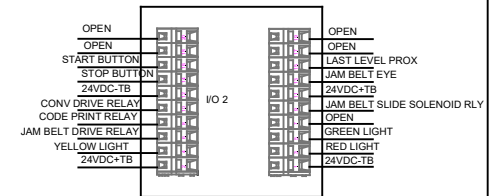
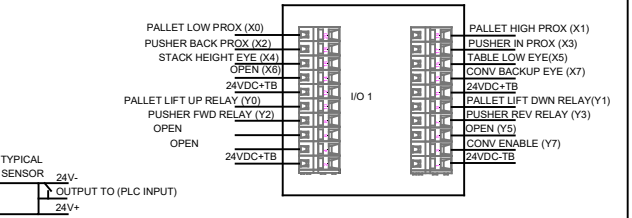
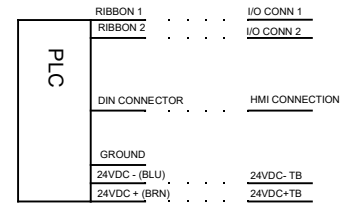

Motor Drive

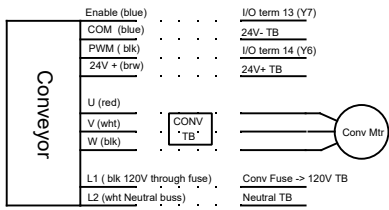

Power distribution

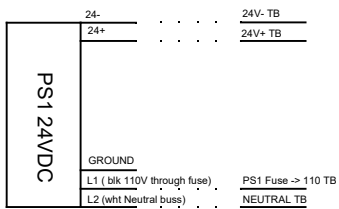
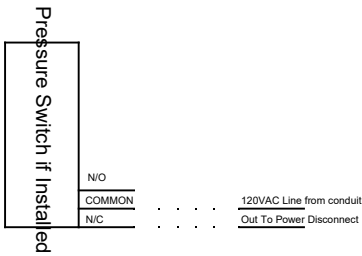
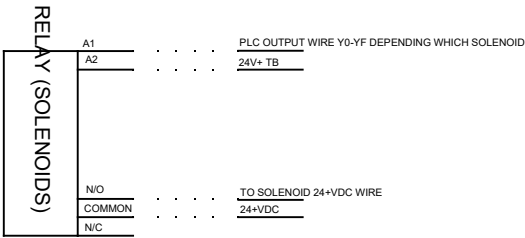

LOGIC I/O

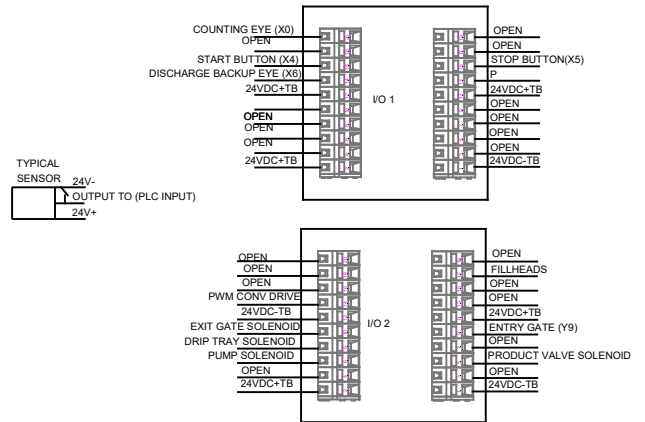
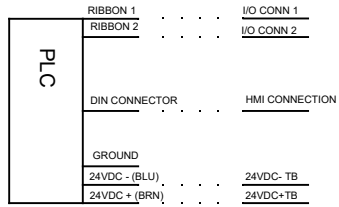

IN-LINE PACKAGING SYSTEMS, INC.

7282 SPA ROAD
 NORTH CHARLESTON, SC 29418-8437

Invoice

Customer No.: IHS

Invoice No.: 20077

Bill To: **INNOVATIVE HANDLING SYSTEMS, INC**
 PO BOX 538
 HEBRON, KY 41048

Ship To: **INNOVATIVE HANDLING SYSTEMS, INC**
 PO BOX 538
 HEBRON, KY 41048

Date	Ship Via	F.O.B.	Terms
09/02/2021		Origin	Net 15
Purchase Order Number	Order Date	Sales Person	Our Order Number
202459-6	09/02/2021		18521

Quantity			Item Number	Description	Serial Number	Unit Price	Amount
Req	Shipped	B.O.					
10	10		TRAVEL X 2	TRAVEL ON SUNDAY OR HOLIDAY		100.00	1000.00
8.000	8.000		TRAVEL HRS	Travel Hours RETURN		70.00	560.00
31.040	31.040		FIELD SERV	Field Service Hours IN PLANT		140.00	4345.60
1.000	1.000		EXPENSES	Billable Expenses Flight		504.96	504.96
1.000	1.000		EXPENSES	Billable Expenses RENTAL CAR		375.89	375.89
1.000	1.000		EXPENSES	Billable Expenses LODGING		829.96	829.96
1.000	1.000		EXPENSES	Billable Expenses MEALS		143.00	143.00

Invoice subtotal 7759.41

Invoice total 7759.41

Thank You

PD Rinsers Motor Drives

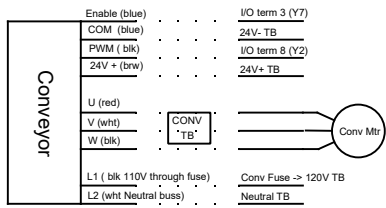

PD RINSER DC distribution

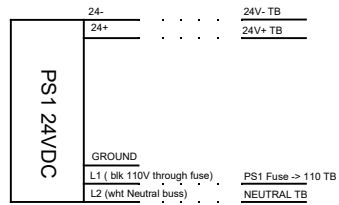
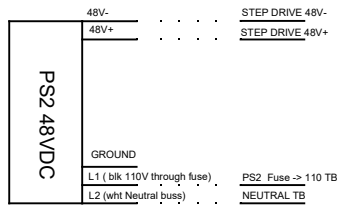
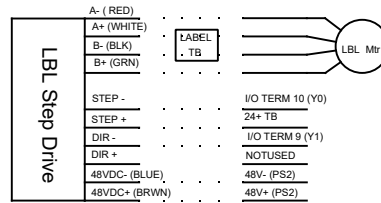

PD RINSER LOGIC I/O

