

Operation Manual

Paradigm 700



Pressure Sensitive Labeler

In-Line Labeling Equipment, Inc.

7282 Spa Road, North Charleston, SC 29418

Phone: 843.569.2530 Fax: 843.569.2531

www.labeling.net

Operation Manual

Paradigm 700



Pressure Sensitive Labeler

In-Line Labeling Equipment, Inc.

7282 Spa Road, North Charleston, SC 29418

Phone: 843.569.2530 Fax: 843.569.2531

www.labeling.net

Persons operating this machinery are reminded to observe their own company safety policies. In addition, the following safety rules should be observed:

DO NOT REACH INTO THE MACHINE WHILE IT IS IN OPERATION.

USE ONLY THE CORRECT TOOL FOR THE JOB BEING DONE.

STAY ALERT, REMEMBER LOCATION OF CONTROL SWITCHES.

MAINTENANCE

The main electric switch supplying power to the machinery should be locked out or disconnected when repairs to work is performed on this equipment.

Machine should be cleaned and inspected regularly. All safety switches must be operable, attachments secure and machine free of broken glass and paper.

Do not hand lubricate when the machine is in operation.

Work area should be kept clean and as dry as is practical.

The repair or adjustment of this equipment should be performed only by persons qualified through technical training and ability, as assigned by your company.

OPERATION

All guards should be securely in place before operating the machine.

Company rules on eye protection should be followed.

Loose clothing or jewelry such as neckties, rolled sleeves, over blouses, bracelets, watches and rings should not be worn when operating the machine.

Report all malfunctions, unusual operation and defects immediately.

Please exercise caution with any moving parts, including the conveyor and any pinch or drive rolls.

Stop the machine before placing hands or arms near or into any area where moving parts are located.



Table of Contents

Section One - General Information

- 1.1 Machine Terminology
- 1.2 Specifications and Requirements
- 1.3 Functional Description of Machine
- 1.4 Basic Machine Controls

Section Two – Uncrating and Installation

- 2.1 Power and Air Connections
- 2.2 Installing in Production Line
- 2.3 Leveling Base Machine
- 2.4 Leveling Label Head/Squaring Peel Plate
- 2.5 Adjust the Wiping Pad

Section Three - Preparing to Label

- 3.1 Loading Label Head
- 3.2 Set Conveyor to Bottle Diameter
- 3.3 Adjust Height of Label on Container
- 3.4 Adjust Web Guides
- 3.5 Adjust Label Gap Sensor for Sensitivity
- 3.6 Adjust Photo Eye for Dispensing of Label

Section Four - Operational Adjustments

- 4.1 Adjusting Label Tracking and Presentation to Product

Section Five - Periodic Maintenance, Cleaning and Lubrication

- 5.1 Maintenance
- 5.2 Cleaning the Machine
- 5.3 Lubrication

Section Six - Troubleshooting

- 6.1 Nothing Works at All
- 6.2 Container Is Detected but no Label Dispenses
- 6.3 More Than One Label Is Dispensed
- 6.4 Web Keeps Breaking
- 6.5 Label Tracking Is Not Square
- 6.6 Labels Are Skewed on Container
- 6.7 Leading Edge of Label Is Buckling and/or Turned Under

Section Seven - Parts Diagrams

Section Eight - Options and/or Specials supplied with machine

Section One – General Information

1.1 Terminology of Labelers

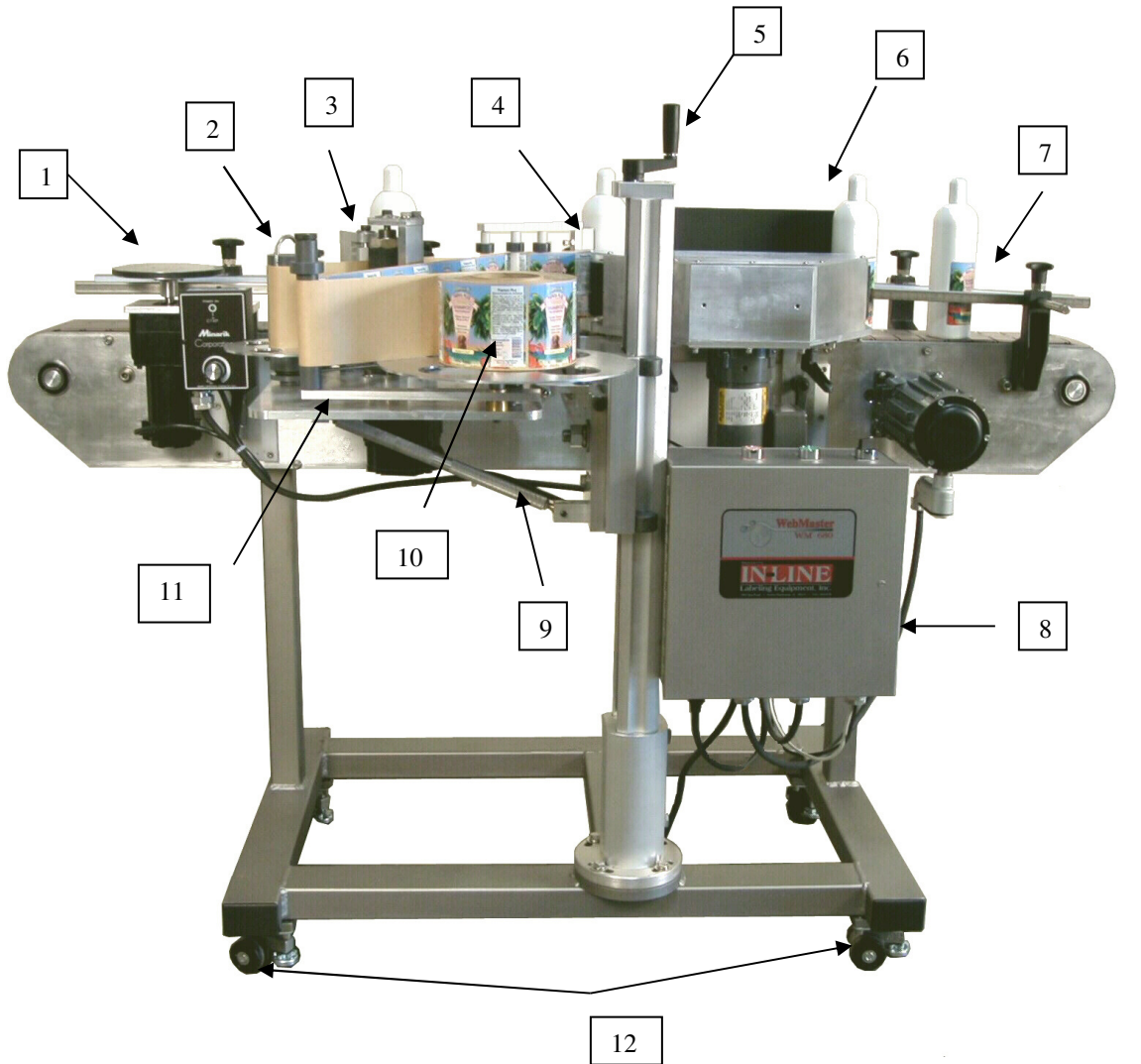

- | | |
|-------------------------------------|-------------------------------|
| 1 Spacing Wheel (<i>optional</i>) | 7 Guide Rails |
| 2 Take-up Reel | 8 Control Box |
| 3 Pinch Grip Mechanism | 9 Turnbuckle |
| 4 Peel Plate | 10 Web Feed Reel |
| 5 Label Head Height Adjustment | 11 Dancer Arm |
| 6 Wiping Station | 12 Locking Casters (Optional) |

1.2 Specifications - Standard machine

Item	Specification
Bottle Dimension	1 inch to 5 inches
Label Height	1 inch to 4 1/2 inches
Label Width (length)	2 inch to 12 inches long
Speed	Fixed at 700 ipm
Maximum Rate	90 Labels/minute
Label Gap	1/8 inch standard (up to 1/4 inch on some)
Core Size	3 inches in diameter
Roll Size	Maximum 12 inches
Product Detection	Photoelectric eye – Polarized Reflective
Label Detection	Photoelectric eye - Through Beam
Power Requirements	120 VAC, 60 hz, 3 amp
Compressed Air	3-4 cfm @ 65 psi if needed for coder

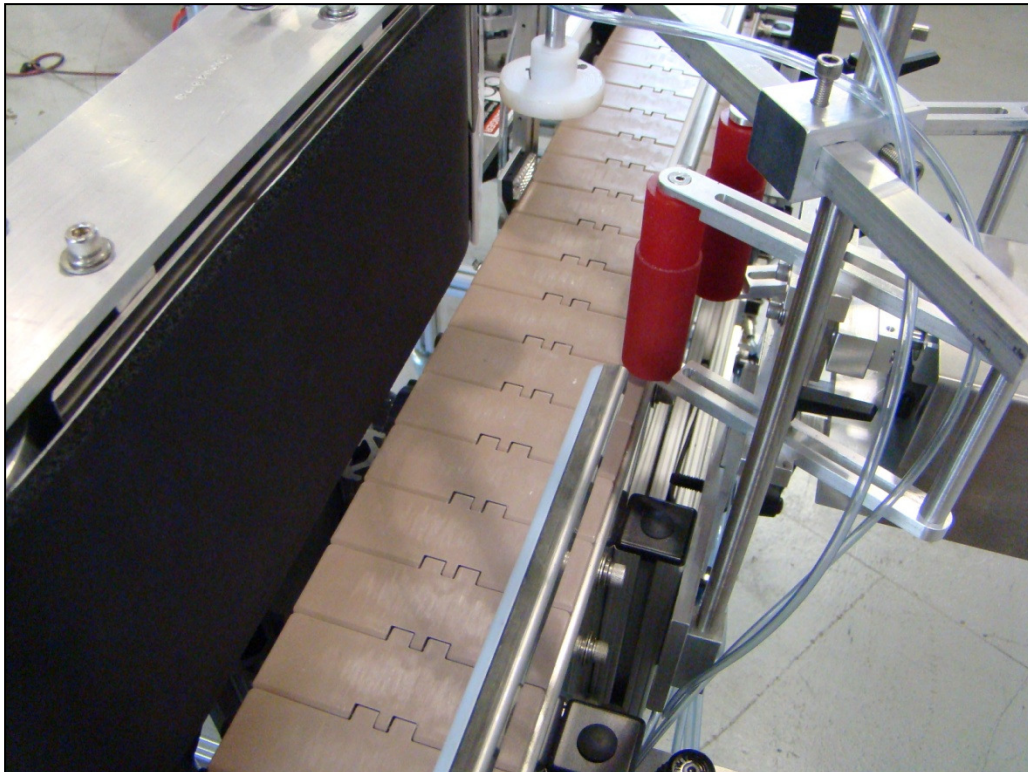

1.3 Functional Description of Machine

The model Paradigm 700 is a fully automatic labeling machine capable of applying labels to cylindrical containers. The machine functions in this manner:

- Products are detected by the Photoelectric Eye as they travel by the Labeling Head.
- This signal initiates the label feed and the label is dispensed from the Peel Plate. The label will continue to dispense until the end of label signal is received from the Label Gap Sensor.
- The Label Gap Sensor is a fork photo eye (through beam). The fork photo eye “sees” through the gap between labels but not through the label when it is correctly adjusted.
- When the Label Gap Sensor detects the end-of-label gap the signal stops the motor that turns the drive roll and the label stops dispensing.
- The Wrap Station “spins” the bottle, wrapping the label around it, by compressing the bottle between the Spin Belt and the Back Compressor Pad.
- The Model 700SP “grips” the bottle against the wrap belt and spins the bottle in place while the label is being dispensed, releasing it when complete.
- When the product being labeled has cleared the photo eye and the label has completely dispensed, the next product can now enter and start the cycle anew.



1.4 Basic Machine Controls

Control Panel

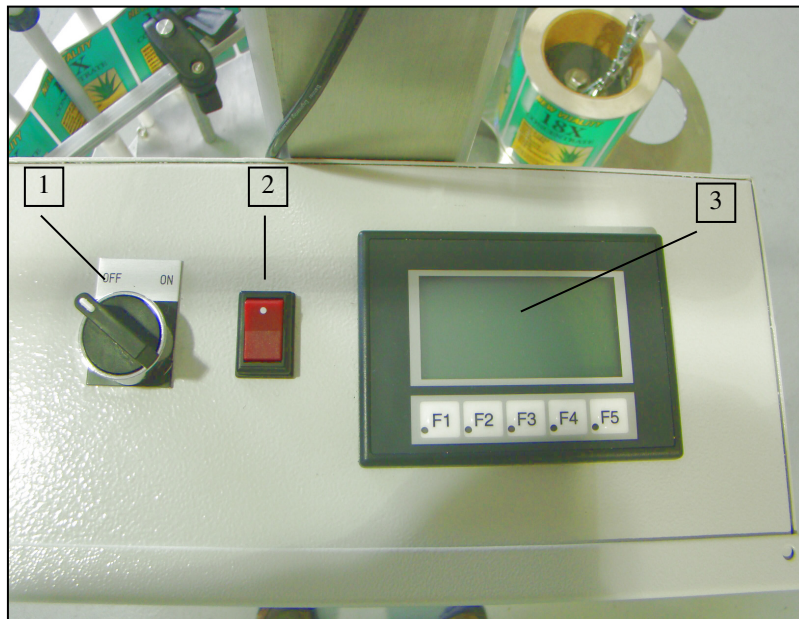

- 1 **Power On/Off Switch**
- 2 Label On/Off Switch
- 3 Operator Interface

Screens

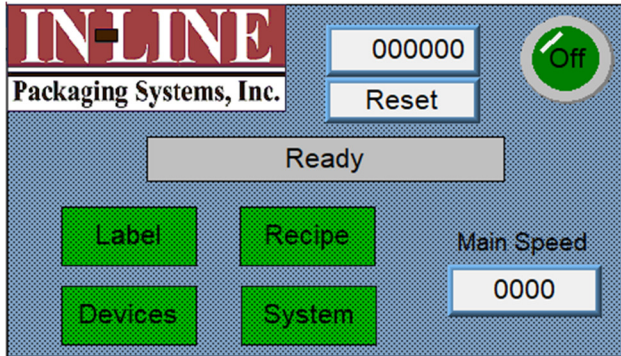

Main Screen

1. Batch count displays the current count of containers. Reset starts the count at 0.
2. Main Speed can be entered in inches/minute.

For all screens

- Label** – Takes you to the Label Screen
Device – Takes you to the Device Screen
System – Takes you to the System Screen
Recipe – Takes you to the Recipe Screen

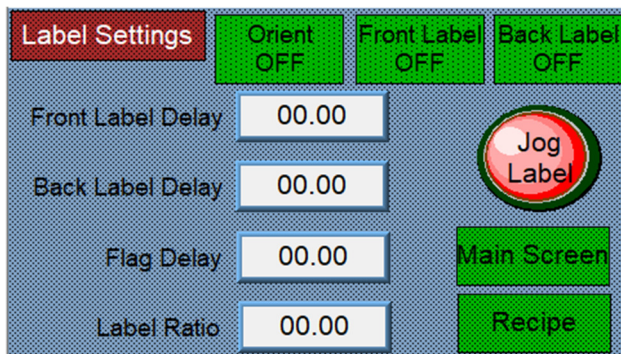

Label Settings

1. Label feed can be turned on or off.
2. Labels can be jogged while the machine is Stopped.
3. Label delay is in counts of the bottle as it spins with 200counts per inch.
4. Flag delay is in steps of label feed with 160 steps per inch.
5. Label Ratio allows the fine-tuning of the speed versus the wrap belt, with 1.0 = 1:1 ratio.

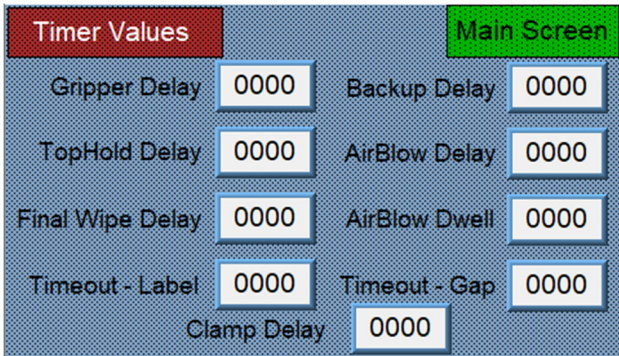

Timer Settings

1. Gripper delay is time after product is detected until gripper extends.
2. TopHold Delay is the delay after gripper extends until tophold comes down.
3. Discharge backup delay is time after eye is blocked until starwheel stops and the same time for restart after eye is open.
4. Final wipe delay is the time after the label is completed until the gripper retracts.
5. No Label Error Delay: If no labels are present in the gap sensor the machine will shut down after this time delay.
6. Gap Detect Error Delay: If a label begins to feed and no gap is detected in this time the machine will stop.

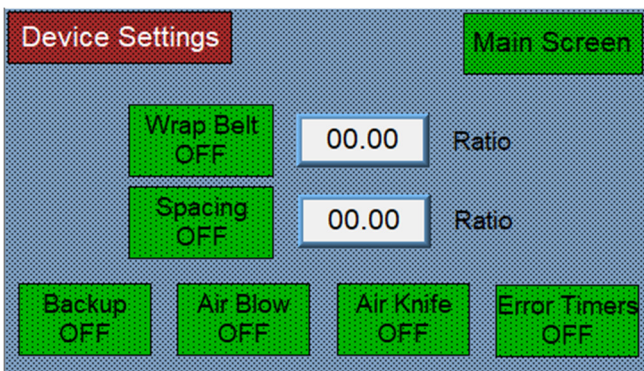

Devices

The various devices on the machine can be enabled or disabled by turning on or off these bits. The status of the bit is retained through power down.

All ratios are in terms of the main speed, with a value of 1.0 equal to a 1:1 ratio. 1.10 would equal 110% of the main speed.

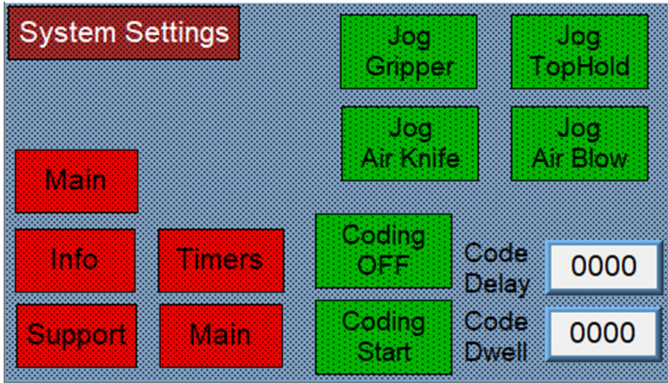

System Settings

1. Jog functions for all the components are located at the top right corner of the screen
2. Coding can be turned ON/OFF and the delay and dwell can be set

Section Two – Uncrating and Installation

2.1 Power and Air Connections

A grounded electrical male plug is provided with the machine, and is connected to the main electrical enclosure on the side of the machine. Plug this into any grounded receptacle. On machines with coders or that require air, an air filter/reservoir with a ¼" male quick disconnect fitting attached, is provided underneath the main electrical enclosure on machines that require compressed air. You can supply compressed air to the machine by either a mating quick disconnect on the end of an air hose, or you can permanently pipe air to the machine using standard pipe and connecting directly into the air filter using threaded pipe connections. If you permanently pipe air into the system we recommend a cut-off valve be mounted at the machine. Some changeover adjustments are easier if the operator is able to temporarily turn off the air pressure.

2.2 Installing in Production Line

Move the machine into its permanent location. Adjust the conveyor height of the machine to match the heights of the adjoining machines as required. Leveling Pads are provided with the 700 Labeler that allow some vertical adjustment. If necessary, make spacing blocks to raise the height. Approximately 12 inches of lineal space is provided on each end of the machine to allow a crossover from or to the next machine. Butt the conveyor ends as close to each other as possible and then use conveyor rails to guide the bottles across narrow dead plates onto the conveyor.



2.3 Leveling Base Machine



Once the machine is installed, level the main conveyor through the machine by using a bubble level. Place the bubble level along the length of the machine and also perpendicular to the conveyor at the label station. Leveling the machine is important to the quality of labeling since this will affect the web path and container path. Verification that the machine is square and level will ensure proper operation.

2.4 Leveling Label Head/ Squaring Peel Plate

Next, level the Label Head itself. This is best accomplished by using a small square (or a machined square finish). Place the square on the conveyor and reference it to the end and side of the peel plate.

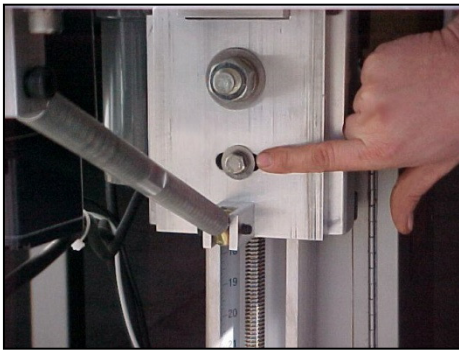
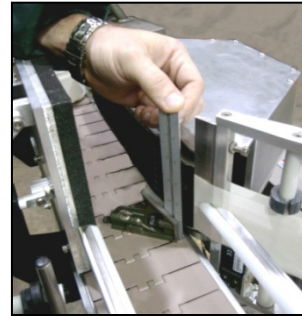

There are two bolts where the Label Head is mounted to the upright stand. The Label Head pivots around the larger bolt. Loosen both bolts and tilt the label station to achieve the desired adjustment for side-to-side.

Underneath the label station is a turnbuckle adjustment. The Label Station Plate pivots at the point of connection to the upright and when lengthening or shortening the turnbuckle, the front-to-back adjustment of the Peel Plate is changed. Adjust the Label Station to move the Label Head until the end of the Peel Plate and the side of the Peel Plate are both square to the conveyor at the point of labeling. This will ensure that the label is feeding off the Peel Plate in a straight fashion onto the product.

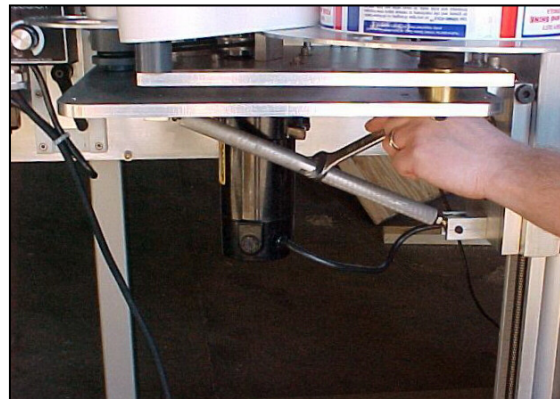

2.5 Adjusting Wiping Pad

To adjust the Wrap Station, loosen the knobs on the brackets and slide the Wiping Pad back away from the Wiping Belt. Place two containers at each end of the Wrap Station and slide the Wiping Pad in until there is light pressure on the bottles with the leading end (closest to the Peel Plate) slightly more open than the opposite end to ensure container enters the Wrap Station with out hesitation. Make sure the Wiping Pad is square to your container by adjusting the knobs that affect the angle of the Wiping Pad. Lock down the adjustment once squareness has been achieved.

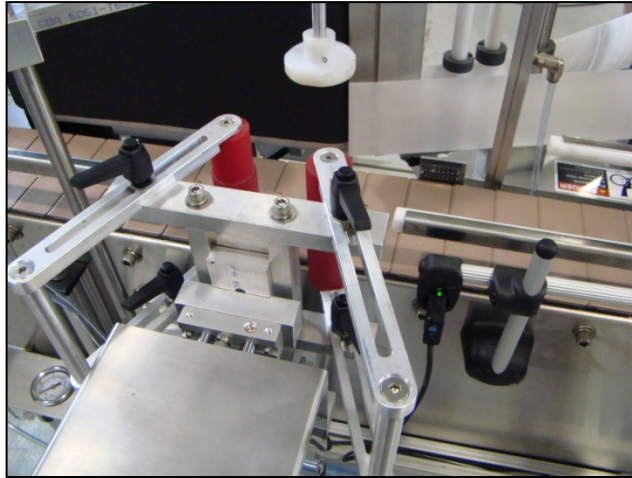

The most common reason for skew in the labels is that the Peel Plate is not square to the conveyor, and labels are feeding out crooked in their relationship to the product.

Section Three - Preparing to Label

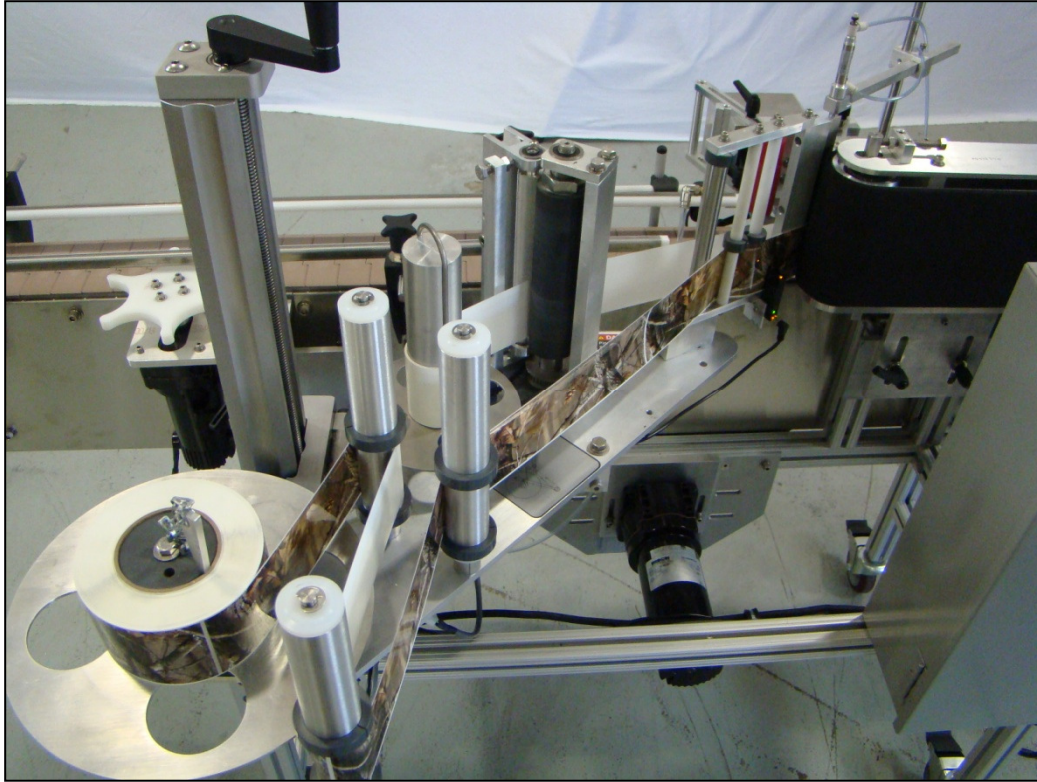

Now that the main conveyor and Label Head have been leveled, the labels can be loaded as shown in the photo or the diagram on the next page. The web is intended to travel at a height exactly 2 inches above the top plate of the Label Station.

3.1 Loading Label Head

1. Slide the web roll down onto the Feed Reel and lock it into place using the key to make sure it does not spin around the hub.
2. Feed the label web around the fixed idler roll and then out to the Dancer Arm. Then feed back to the outside idler roll and then into the peel plate assembly.

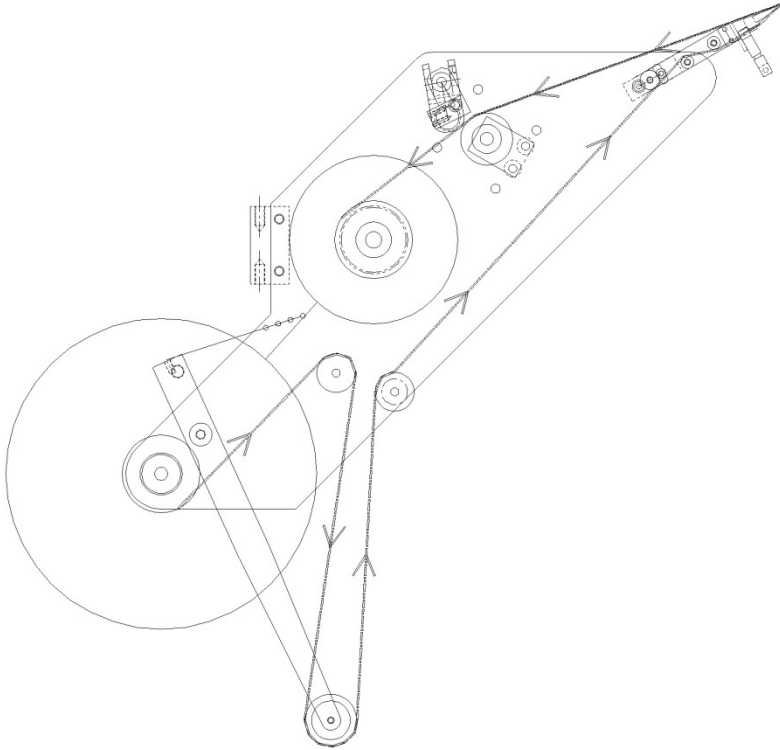

3. Feed the web behind the first white delrin guide in the peel plate assembly then in front of the first white delrin guide.
4. Insert the web into the slot in the Label Gap Sensor.
5. Bend the web around the edge of the Peel Plate and along the opposite face of the Peel Plate post.
6. Be sure that the Pinch Roll Lock is released and insert the web between the Knurled aluminum roll and the Drive Roll.
7. Attach the web to the take-up reel with the supplied "Shepherd's Hook".
8. Be sure that all of the Guide Clips are correctly placed to maintain proper label height along the complete web path.
9. Finally, reengage the Pinch Roll Lock and rotate the Feed Reel to remove any slack.

The Model 700 Web Path.

3.2 Set Conveyor to Bottle Diameter

The conveyor guides must be set to the bottle diameter to ensure smooth control of the containers into and through the labeler. The right side of the labeler is fixed, that is, the side from which the label is applied is fixed to the conveyor. All adjustments to the Conveyor Guides should be from the left side of the machine. Adjust by loosening the knobs holding the rods attached to the rail and then slide the rod in or out. Tighten the handle once complete. The correct distance for a diameter should be about $\frac{1}{8}$ " to $\frac{1}{4}$ " greater than the diameter of the container.

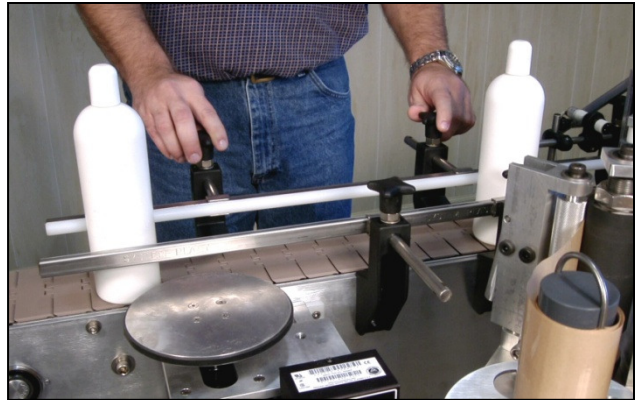

3.3 Adjust Height of Label on Container

The entire Label Station moves up and down to move the label location vertically on the product. Place one of the products to be labeled on the conveyor by the Applicator Roll (with the machine turned off). Now you can use the hand crank located at the top of the stand to adjust the height of the entire labeling head. Adjust until the label is located where you desire.

3.4 Adjust Web Guides

There are several plastic Web Guides on the vertical PVC rolls that guide the web through the machine. These Web Guides help to keep the label web tracking through the machine at the same height. This is essential to consistent labeling. The lower edge of the label web is 2 inches from the top of the Label Plate and so the lower Web Guides should be at that level. These can be measured with a ruler. The top Web Guides can then be moved up or down depending on the height of the label web being run. They should be positioned to allow $\frac{1}{16}$ " clearance of the web. If the web rides up or down, these guides will help hold it in place.



3.5 Adjust Label Gap Sensor for Sensitivity

Position the arrow on top of the Label Gap Sensor so that it is in the gap between the labels. Press the “normal” button, which is on the top, for normal, opaque labels on white liner. The “translucent” button should be used for brown Kraft liners and/or for labels that are not opaque.



3.6 Adjust Photo Eye for Dispensing of Label

The Labeling Head on your model 700 Labeler comes with a Photo Eye that uses diffusive reflectivity to detect the product. It is mounted to the side of the conveyor opposite the Labeling Head to the right of the Wiping Pad and points directly across the conveyor path.

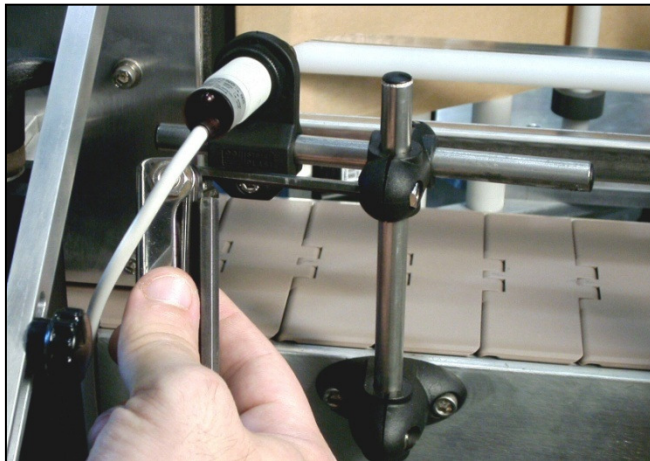

This Photo Eye can be pivoted slightly on its mounting bracket to advance or retard the detection of the product and the dispensing of each label. The ideal setting is for the label to begin feeding and meet the widest part of the bottle as it passes the peel plate. This setting will provide the most consistent labeling.

Section Four - Operational Adjustments

4.1 Adjusting Label Tracking and Presentation to Product

The tracking of the label through the machine is extremely important to consistent labeling. If the label web “rides” up or down then the label will generally be skewed to one side or the other. The presentation of the label to the product is also paramount. If the machine is set up correctly, the web will track consistently at the same height through the machine riding on the web guides and around the peel plate and the label will be presented squarely to the wall of the product to be labeled. With it set up this way consistent labeling will be achieved. There are two major factors to consider in labeling consistency:

1.) The Label Web Is Tracking Up and Down:

This changes the relative height on the product. If this is the case, then uneven pressure or pull is being exerted on one or more points of the web which causes it to move up or down.

Here are some potential points to check:

- The web guides being out of alignment. *(To correct please refer to section 3.4)*
- The pinch roll being out of alignment and putting more pressure or not enough pressure on the bottom (or top) of the web when it pinches. *(Turn the stop screw located at the base of the knurled roll to the right to increase pressure and to the left to decrease pressure.)*
- The take-up reel being too high or low. *(The take-up reel should be 2 inches from the base plate to the top of the take-up reel plate.)*
- The peel plate not being “square”. *(To correct please refer to section 2.4)*
- Pressure in the wrap station causes the bottle to “ride up” or corkscrew up which is reflected in the skew of the label. *(To correct please refer to section 2.5.)*

Any of these factors will cause the label web to establish and track at an angle up or down. The obvious symptom is skew of the labels in a predictable fashion, leaning to one side on the product in the same way as each product that is labeled.

2.) The Squareness of the Peel Plate to the Wall of the Product:

If the peel plate is angled versus the wall of the product, then the label will feed out angled onto the container. This can be checked by using a square placed on the conveyor resting against the very end of the peel plate. Place the square on the conveyor and reference it to the end and side of the peel plate.

There are two bolts where the label head is mounted to the stand. The label head pivots around the larger bolt. Loosen both bolts and tilt the label station to achieve the desired adjustment. Adjust the label station and

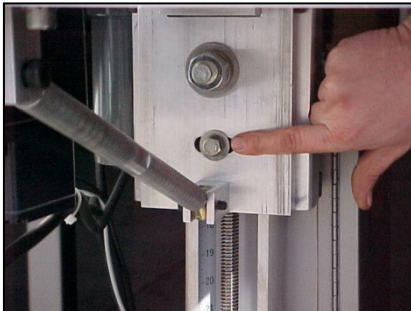
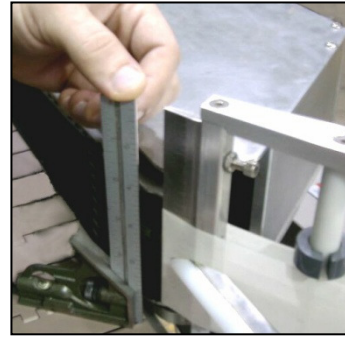

move the label head until the end of the peel plate and the side of the peel plate are square to the conveyor at the point of labeling. This will ensure that the label is feeding off the peel plate in a straight fashion onto the product. Also check the turnbuckle adjustment.

There will always be some variance from label to label, which is due to the numerous variables of paper, container, machine, etc. In an ideal world the variance will be normally distributed: for example, if 100 products are labeled, the skew will be equally on one side or the other with the average being exactly in the middle (no skew). If plotted, it would appear as a bell-shaped curve.

The rule of thumb is this: if the skew is always to one side or the other then there remains some set-up problem or deficiency that is causing it.

Section Five - Periodic Maintenance, Cleaning and Lubrication

5.1 Maintenance:

There are very few maintenance items on the 700 Labeler. The three main factors to consider are:

1. Clean the Drive Roll regularly. As the machine is used you will notice a film or line around the black Drive Roll. This is usually from the extra adhesive that has oozed out from under the labels. This buildup of adhesive and dust that sticks to it can create problems with labels sticking to it, or the drive or applicator roll slipping on the product or label. Clean the roll with mineral spirits, or acetone (whatever breaks down the adhesive best) and a clean rag. Doing this regularly will prevent problems. “Goop” hand cleanser and “Goo Gone” also work well. If using a petroleum solvent like acetone or mineral spirits, follow that by cleaning the rolls with a soapy water solution.
2. Drain the Air Inlet Filter and reservoir. Compressed air typically has some condensation in it and your labeler has a drain trap for that. Turn the small knob in to allow the trapped water to drain out every day. The morning is the best time.
3. Periodically the Peel Plate will need to be changed. Paper is abrasive and over time and use will wear the stainless steel Peel Plate. To change the Peel Plate, remove the socket head cap screws and the old plate. Install a new plate and fasten it in place with the socket head cap screws.

5.2 Cleaning the Machine:

The 700 Labeler is best cleaned with soapy water or general purpose cleaner. Regular cleaning of the machine is recommended.

5.3 Lubrication:

The only lubrication points on the machine are:

1. The Web Hub Shaft (Feed Reel) sometimes needs thin oil lubrication to keep it from sticking and the Feed Reel moving freely. Lift it up and apply the oil to the post.
2. The Drive Sprockets inside the frame of the machine may need some grease once/year. This is #35 chain and sprockets.

Section Six - Troubleshooting

6.1 Nothing Works at All

- a) Check main power. Is machine plugged in? Is main power switch turned on?
- b) Check fuses inside control panel. Bad fuses will be indicated by the red LED on the fuse holder.
- c) Are labels loaded in the machine? If the label gap sensor is “open” then an error circuit prevents the motors from turning after 5 seconds.
- d) Are speed controls turned up above zero?

6.2 Container Is Detected but no Label Dispenses

- a) Is the Label Gap Sensor in the gap between labels or “uncovered”? There is an error feature in the machine that prevents the motors from turning whenever the gap is open for more than 5 seconds.
- b) The sensitivity of the Label Gap Sensor may need adjusting. If the Label Gap Sensor is a micro switch it may need adjusting in, if the sensor is a photo eye it may need the sensitivity reduced.

6.3 More Than One Label Is Dispensed

- a) Check the sensitivity of the Label Gap Sensor. If it is a photo eye then the sensitivity may need to be increased so the photo eye will “see” through the web backing.
- b) There may be too much “flag” of label, and the second label is getting stuck to the product and pulling off the web by the product rotation.
- c) The photo eye may be set so that the product is being seen more than once, and the machine is labeling the same product again and again. You should be able to see the machine “cycle” in between labels, with a small pause.

6.4 Web Keeps Breaking

- a) Check the label web (backing paper). Is it scored, torn, or creased? If so replace with another roll of labels and try again.
- b) Check the edge of the Peel Plate. Is there a burr or sharp edge that may be cutting the web? If so then take a piece of emery cloth or very fine sandpaper and lightly sand the edge.
- c) Check the travel of the label path. Sometimes the label web may get “hung” on a Web Guide or be binding in a way that will cause the web to break when the Pinch Roll engages. This will cause it to break at the Peel Plate.

6.5 Label Tracking Is Not Square

- a) Check the path of the label web. Is it tracking straight? Are the Web Guides holding the web at a consistent height through the machine? Adjust accordingly.
- b) Check Web Guides to ensure that they are holding the label web down.
- c) Check the Peel Plate to be sure it is square in relation to the conveyor.
- d) Check the Drive Roll to see if adhesive build-up is causing the label web to be pulled up as the label web is pulled through the Pinch Mechanism.

6.6 Labels Are Skewed on Container

- a) Check the skew to see if it is all the same direction and about the same amount. If so, then check to see if the Peel Plate is square to the container. Use the turnbuckle to adjust the angle of attack of the label.

6.7 Leading Edge of Label Is Buckling and/or Turned Under

- a) Are the labels “floppy”, as in film or vinyl label material? This will contribute to this tendency. Check to see if they can be ordered with thicker material.
- b) Has the die cut of the label shape creased or scored the web backing. This will “push” the edge of the label into the backing and causes it to hesitate when being separated from the web.
- c) Is the label “flagged” too much? If so the incoming product may be folding the edge over.
- d) If the label feed begins too early, the leading edge may not be completely attached and it will fold over when it hits the back wiping pad.

6.8 Wrinkles in the Middle of the Label.

The transition of the bottle out of the conveyor Guide Rails and into the Wrap Station must be as smooth and as uninterrupted as possible. If the bottle bumps against the edge of the Wiping Pad, a wrinkle will frequently result 1 to 2 inches in from the leading edge. Make sure the bottle moves smoothly through the area where it is detected, where the label feed begins, and when it starts the spin in the wrap station.

Section Seven – Parts Diagrams

Section Eight - Options and/or Specials Supplied with Machine